

biamped active subwoofer

218SA

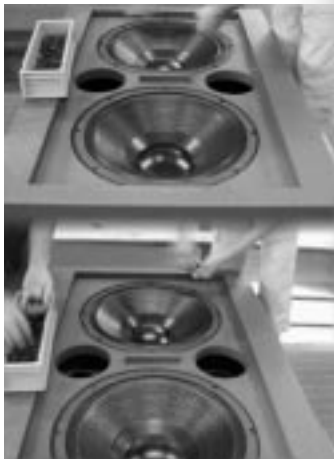

218SA

1500 W continuous

2300 W peak

biamped processor controlled active subwoofer with built-in STEREO electronic cross-over

Designed to give the best in the most exhausting applications, 218SA comes already wired and adjusted for being used in perfect synergy with any loudspeaker system regardless of model and manufacturer. Its features make it the optimum

choice for fixed installations and large touring systems as well as an ideal component for a rental company's sound system.

Montarbo



218SA

ENGLISH

- Two 18" doped paper cone woofers, custom built to Montarbo specifications.
- Two MosFet Class AB power amplifiers (2 x 750 W continuous, 2 x 1150 W peak).
- Two dedicated processors.
- High slope 24dB/oct stereo electronic X-over.
- The cabinet is built with birch multiply, as are the many internal bracings designed to increase stiffness and rigidity of the box.
- Easy to transport thanks to 4 sturdy castors.
- The rear panel features:
 - Balanced XLR sockets for the stereo input and for the link output (which allows the parallel connection of other systems),
 - Unbalanced XLR sockets for the stereo crossover output,
 - Flat / X-Over selector,
 - Input level control,
 - Ground lift switch,
 - The mains power connector is a Neutrik PowerCon®, which guarantees a reliable vibration-proof, contact.

ITALIANO

- Due woofer da 18", impermeabilizzati, costruiti su specifiche Montarbo.
- Due amplificatori di potenza a MosFet in classe AB (2 x 750 W continui, 2 x 1150 W di picco).
- Due processori dedicati.
- Cross-over elettronico STEREO a 24dB per ottava.
- Cabinet in multistrato di betulla, irrigidito da numerosi piani di rinforzo interni conformati nel rispetto dei parametri acustici del sistema.
- Facile da trasportare grazie a 4 robuste ruote.
- Il pannello posteriore dispone di:
 - Prese XLR bilanciate per l'ingresso stereo e l'uscita 'link' (per il collegamento in parallelo di più sistemi),
 - Prese XLR sbilanciate per l'uscita stereo
 - Selettore Flat / X-Over,
 - Controllo livello ingresso,
 - Presa di alimentazione con connettore Neutrik PowerCon® che garantisce un contatto affidabile anche in presenza di forti vibrazioni.

DEUTSCH

- Zwei isolierte 18" Tieftöner, die nach unseren Angaben speziell gefertigt wurden.
- Zwei MosFet Leistungsverstärker in Klasse AB (2 x 750 W Dauerleistung, 2 x 1150 W Spitzenleistung).
- Zwei individuelle Prozessoren.
- Elektronische STEREO Frequenzweiche zu 24dB pro Oktave.
- Gehäuse aus Birkenholz das mit zahlreichen internen, an strategischen Punkten angebrachten und ebenfalls aus Birkenholz gefertigten Verstärkungen versteift wurde.
- Leichter Transport dank der vier robusten Rollen.
- Das Anschlußfeld verfügt über:
 - Symmetrische XLR-Buchsen für den Stereoeingang und für den Parallelanschluß mehrerer Systeme (Link),
 - Unsymmetrische XLR-Buchsen für den Stereoausgang,
 - Einen Flat / X-Over Wählschalter,
 - Eine Kontrolle des Eingangspegels,
 - Erdungsschalter,
 - Eine Zufuhrbuchse mit Neutrik PowerCon® Verbinder, der auch bei starken Vibrationen einen zuverlässigen Kontakt gewährleistet.

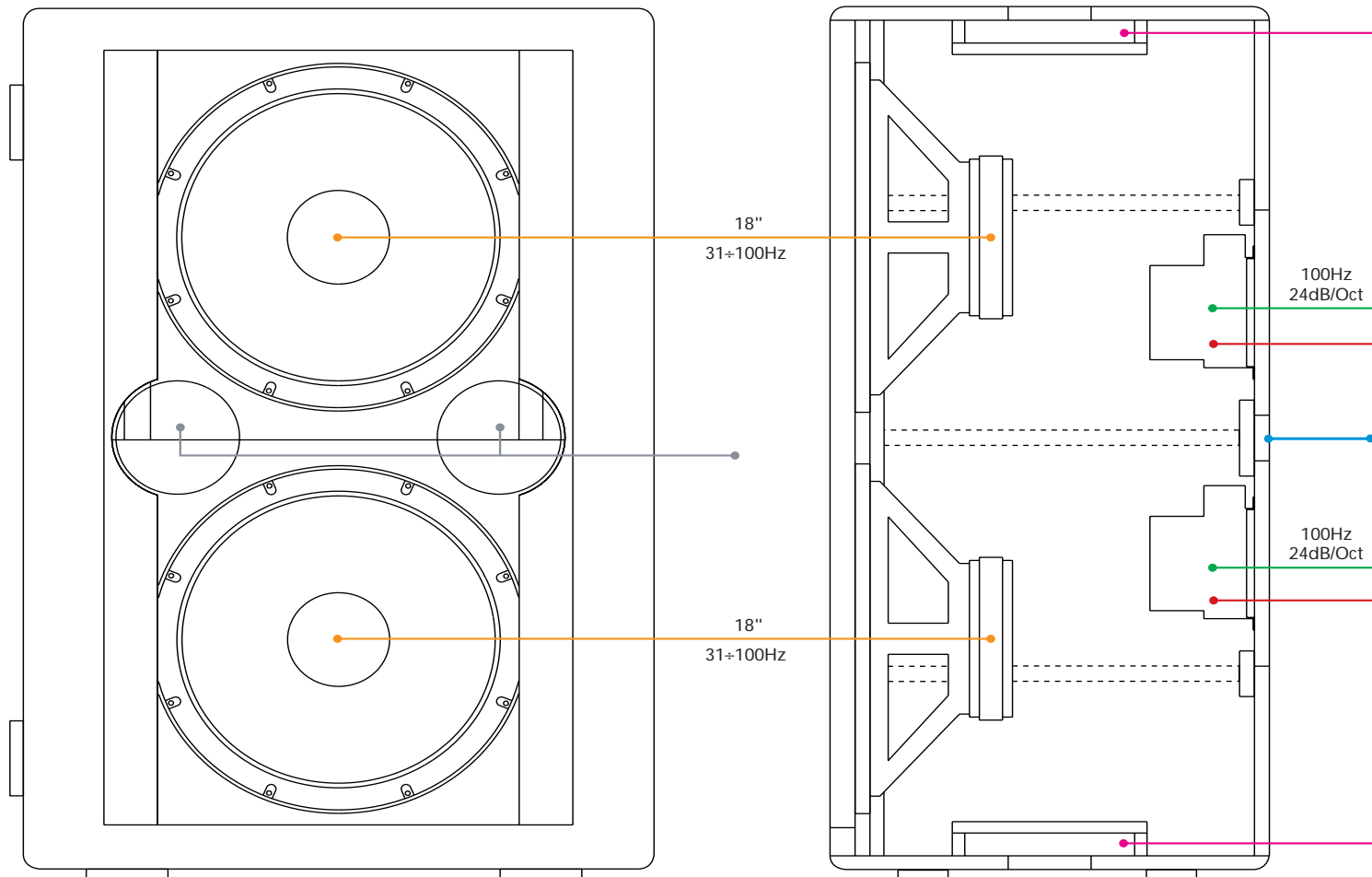

Biamped active subwoofer

ESPAÑOL

- Dos woofers de 18", impermeabilizados, contruidos según nuestras propias especificaciones.
- Dos amplificadores de potencia MosFet en clase AB (2 x 750 W continuos, 2 x 1150 W de pico).
- Dos procesadores dedicados.

- Crossover electrónico ESTÉREO de 24dB por octava.

- Caja de multicapa de abedul, reforzada por numerosos planos internos, (también de abedul) diseñados en el respecto de los parámetros acústicos del sistema.

- Fácil de transportar gracias a 4 ruedas robustas.

- El panel de conexiones dispone de:
 - Tomas XLR balanceadas para la entrada estéreo y para la conexión de varios sistemas en paralelo (link),
 - Tomas XLR desbalanceadas para la salida estéreo,
 - Selector Flat / X-Over,
 - Control de nivel en entrada,
 - Ground-lift,
 - Toma de alimentación con conector Neutrik PowerCon® que garantiza un contacto seguro incluso cuando se verifican fuertes vibraciones.

FRANCAIS

- Deux woofers de 18" , imperméabilisés, construits selon nos spécifications.

- Deux amplificateurs de puissance à MosFet, de classe A-B (2 x 750 W continus, 2 x 1150 W pointe).

- Deux processeurs spécialisés.

- Crossover électronique STÉRÉO à 24dB par octave.

- Baffle en bouleau multiplis, raidi par plusieurs couches internes de renfort (également en bouleau) placées dans les points stratégiques, dans le respect des paramètres acoustiques du système.

- Facile à transporter grâce aux 4 roues robustes.

- Le panneau de contrôle est équipé de:
 - Prises XLR symétriques pour l'entrée stéréo et la connexion de plusieurs systèmes en parallèle (link),
 - Prises XLR asymétriques pour la sortie stéréo,
 - Sélecteur Flat | X-Over,
 - Commande du niveau d'entrée,
 - Ground-lift
 - Prise d'alimentation avec connecteur Neutrik PowerCon® qui assure la fiabilité du contact même en présence de fortes vibrations.

- Control and connection panel
- 2 high efficiency custom woofers
- Electronic crossover
- Transport handle
- Processor controlled Mosfet power amplifier (class AB)
- Tuning ports

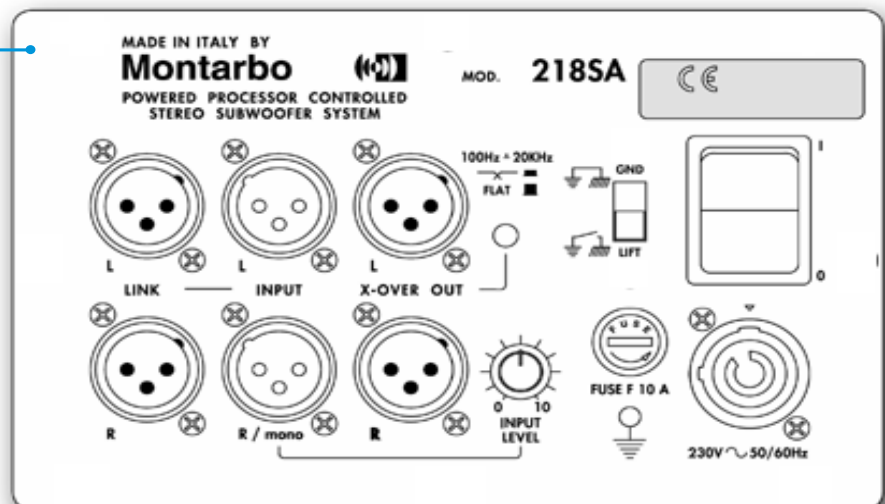

218SA

Designed and manufactured in Italy by:

Montarbo



Elettronica Montarbo srl
40057 Cadriano Granarolo Emilia Bologna (Italy)
phone: +39 051 766437 fax: +39 051 765226
e-mail: mail@montarbo.com internet: www.montarbo.com

Specifications and features are subject to change without prior notice.
The contents of this publication may not be reproduced in any manner without
prior written permission of Elettronica Montarbo srl. All rights reserved.



2 W20A + 1 sub 218SA

SPECIFICATIONS

SPECIFICATIONS

- **Enclosure:** bass-reflex
- Components: 2 x 18" doped paper cone woofers, precision built to Montarbo specifications.
- Power handling: 2 x 1000 Watt
- Impedance: 2 x 4 ohms
- Frequency response: 31Hz ÷ 100Hz / 3dB
- Sensitivity (1W, 1m): 106 dB (half space)
- Max SPL: 137 dB
- Construction: phenyl-glued multiply birch polyurethane paint powder coated steel protection grille
4 castors + 4 recessed handles
- Electronic stereo X-over: 100Hz, 24dB/Oct
- **Built-in amplifiers:** 2 Class A-B MosFet amps, controlled by 2 independent processors.
- Max output power: 1500 W continuous / 2 x 750 W (4 Ω / 0,1% THD)
2300 W peak / 2 x 1150 W
- Input impedance: 10KΩ (balanced)
- Input sensitivity: 0dB (775mV)
- Equivalent input noise: -110dB (A weighted)
- Connections:
 - X-over stereo input XLR balanced
 - X-over stereo output XLR unbalanced
 - 'Link' stereo output XLR balanced
 - mains power connector Neutrik PowerCon®
- **Dimensions (wxhxd):** 113,5 x 76,6 x 66 cm
- **Weight:** 103 Kg

RECOMMENDED COMBINATIONS:

Like many Montarbo products, the 218SA comes packed with a full electronic system inside, factory wired and exactly tuned for maximum ease of operation allowing it to be used with loudspeakers of any make and model. Within Montarbo's range of self-powered loudspeaker systems the 218SA can be the perfect companion for W20A, W18A, W15A, W12A, W17A and W14A.