

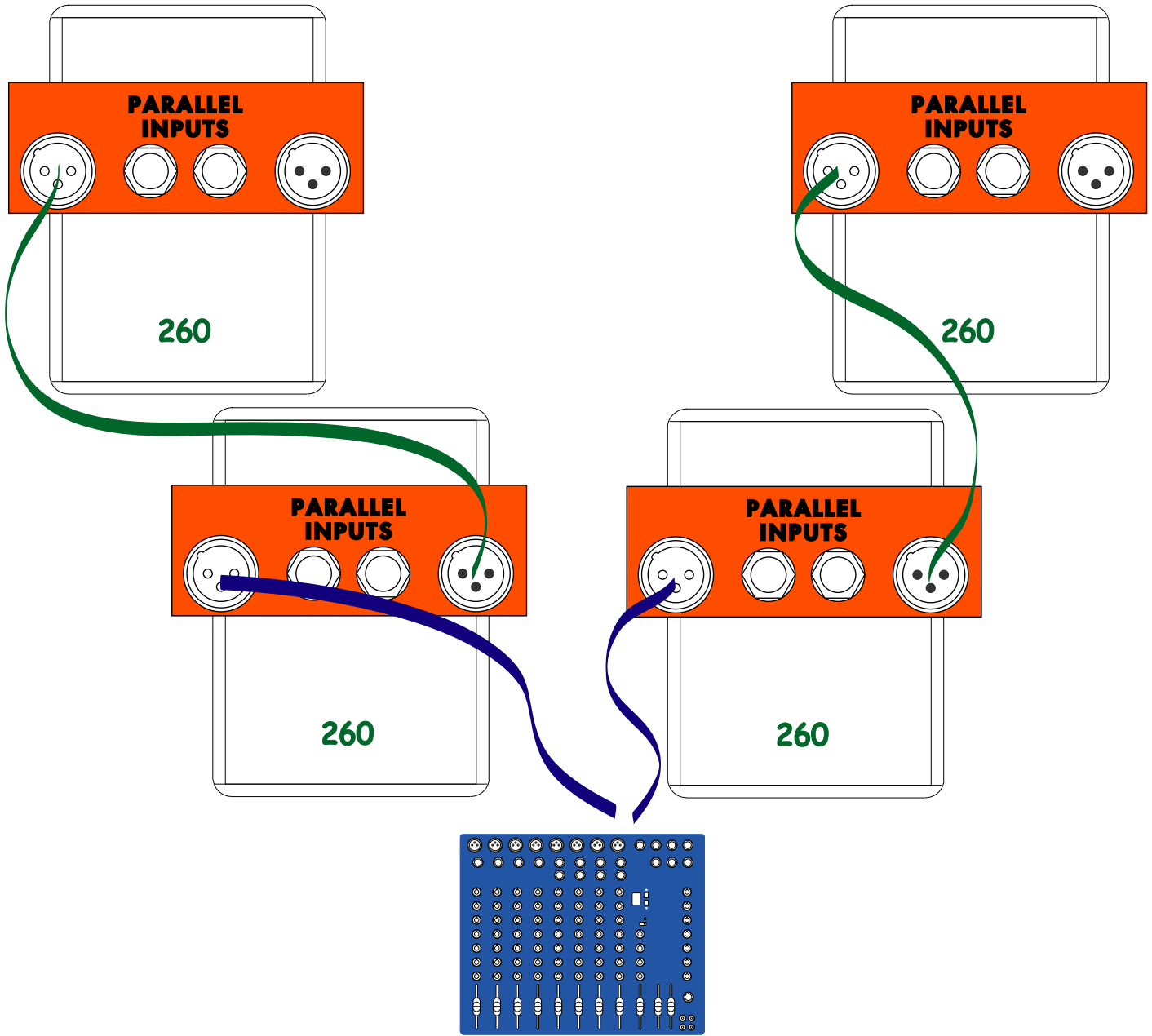

Parallel connection of two or more 260

use only loudspeaker cables (unscreened)

use either Jack or XLR connectors



POWERED MIXER

MIXER L/R POWERED OUTPUTS → 260 INPUTS
 260 INPUTS → INPUTS of other 260



Two 260 + one active subwoofer

for the connection to the 260 use only loudspeaker cables (unscreened)

for the connection to the subwoofer always use balanced shielded cables

260: use either Jack or XLR connectors

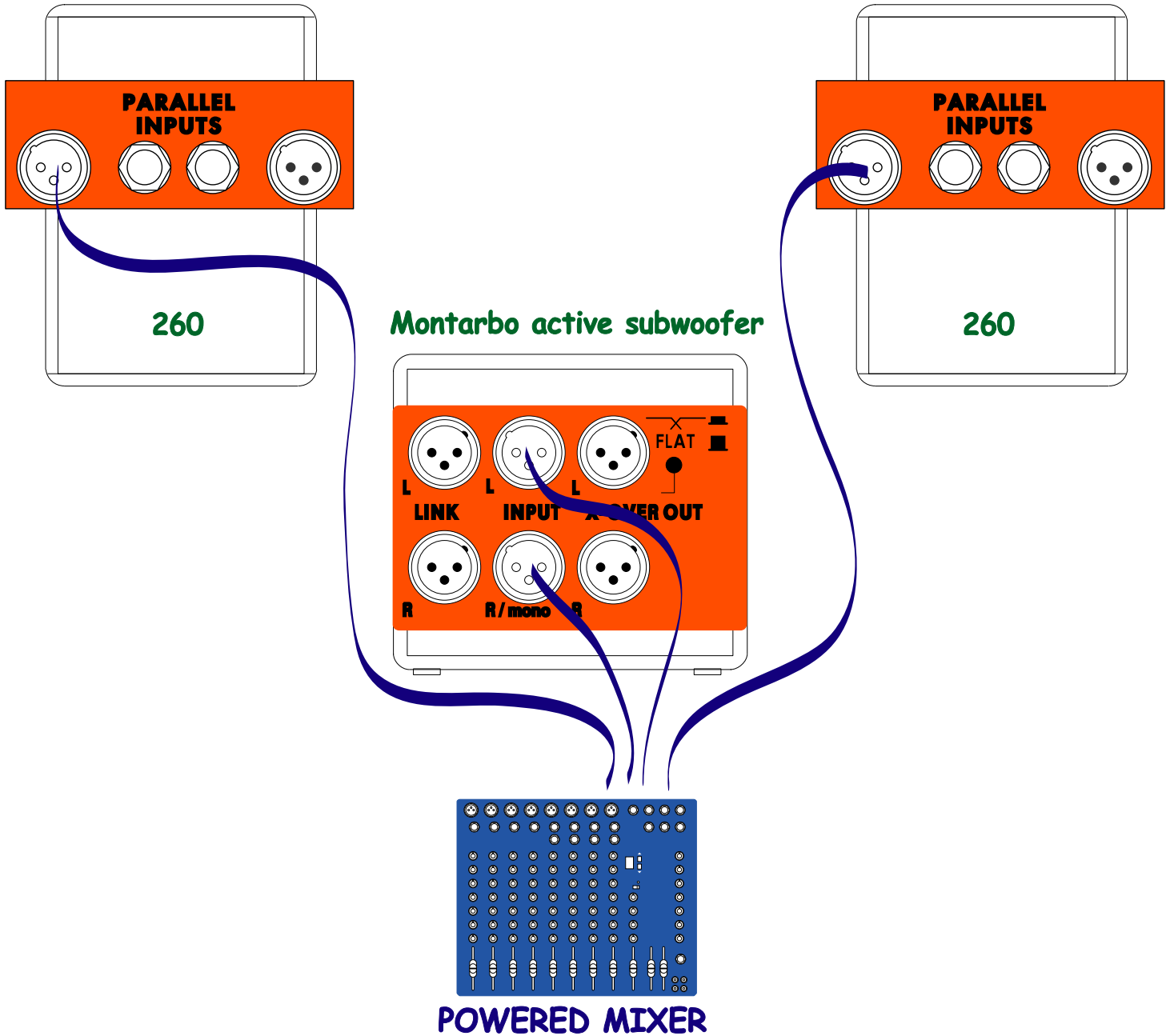

MIXER L/R POWERED OUTPUTS → 260 INPUTS

MIXER L/R NON POWERED OUTPUTS (insert out) → ACTIVE SUBWOOFER INPUTS