

312A control and connection panel

Balanced XLR male (out) and female (in) sockets. This allows for easier parallel connection of more systems.

Mains power switch.

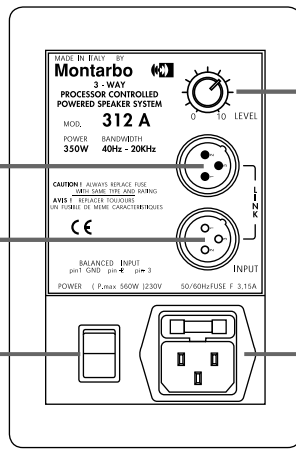

Main volume. Adjusts the input level of the built-in power amplifier to adapt it to the output level of the mixer.

Power supply socket, with built-in fuse.

312 control and connection panel

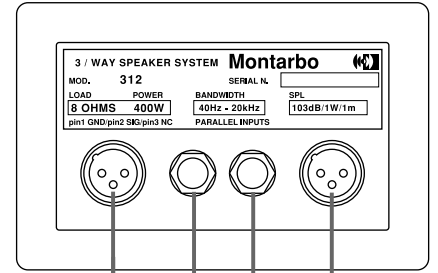

XLR and Jack input sockets wired in parallel.

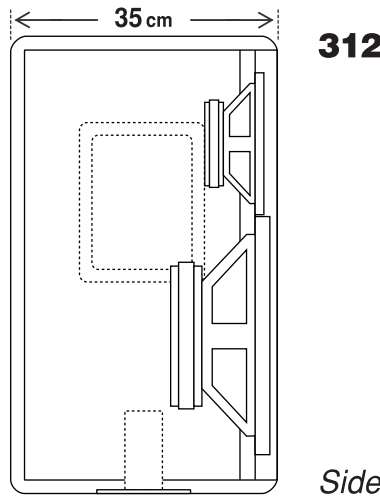
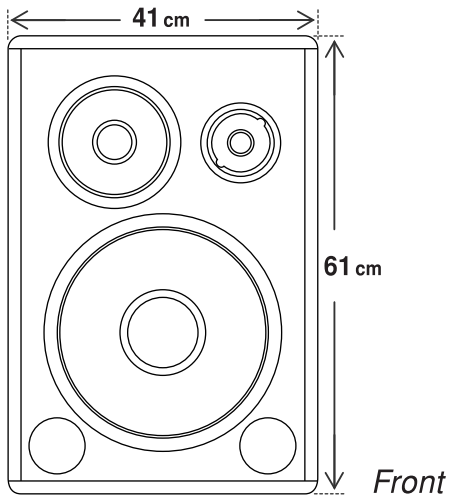

312/312A