

Front view

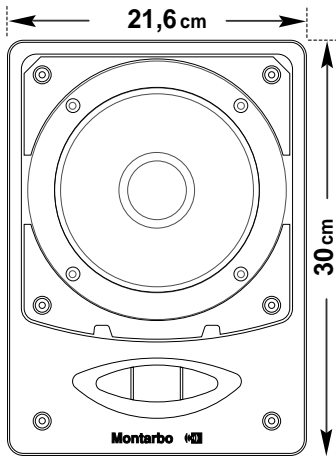

Side view

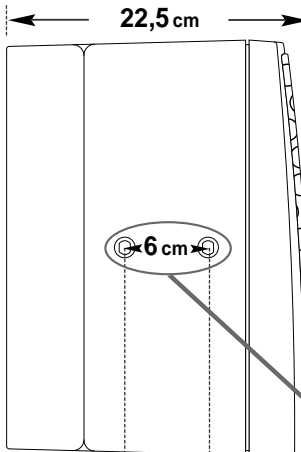

Bottom view

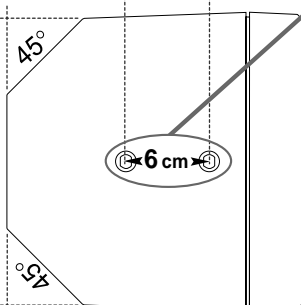

Mounting hardware: threaded inserts
 5 MA lead
 distance 60 mm
 max screw length 12 mm.