

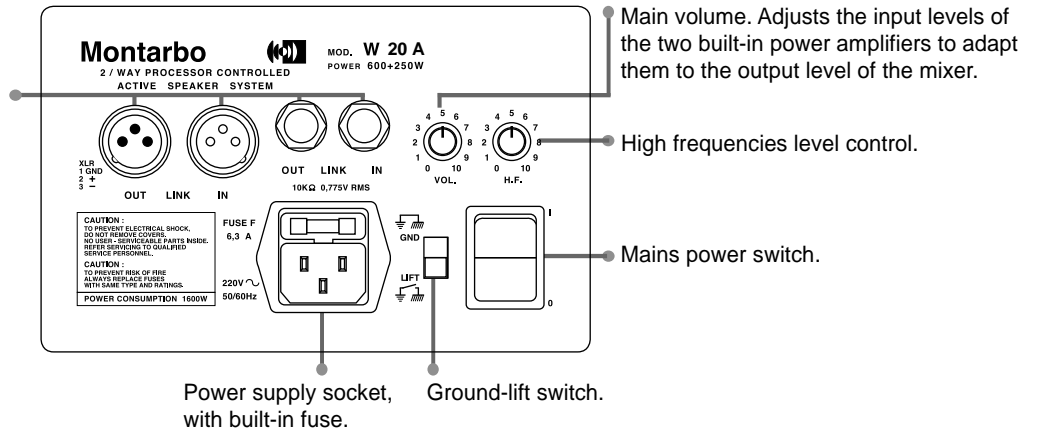

W20A

biamped, 2-way active system with 2 power amps, 2 processors and electronic cross-over

Balanced XLR male (OUT) and female (IN) sockets with balanced jacks wired in parallel. This allows for any combination of Jack or XLR connections, and for easier parallel connection of more W20A active systems.



Front view

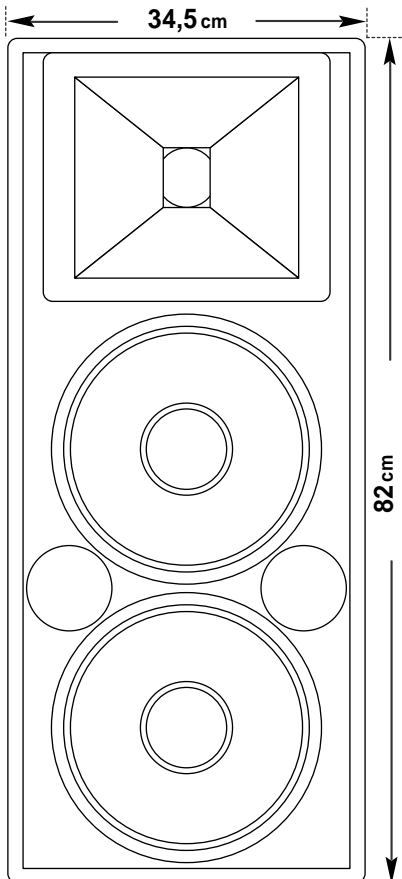

Side view

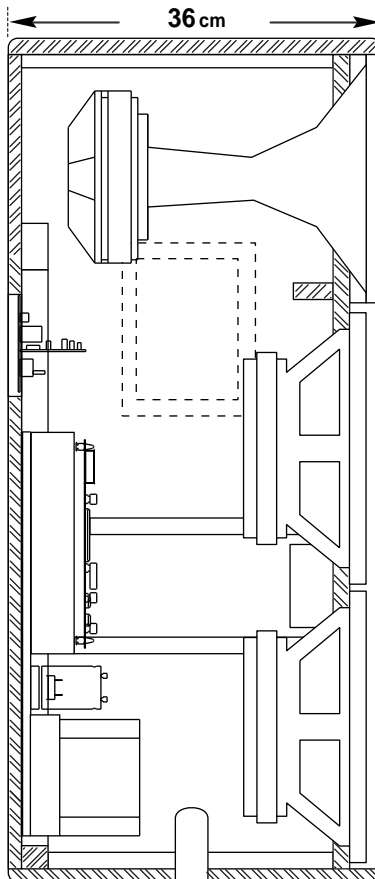

Top view

